



# Stainless Steel Swing Check

**Model #230/234, 330/334, 430/434**

**Class 150-300 (1/2" to 2")**

**Class 600 (1/2" to 1")**

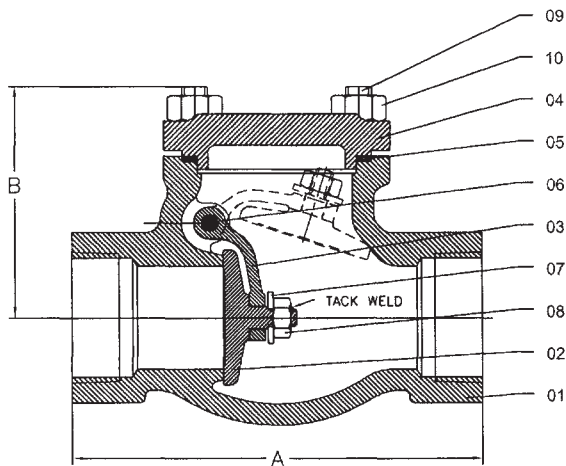

- Threaded and socket weld**
- Unique full port**
- Heavy duty cast construction**
- Bolted cover**
- Precision machined self-aligning disc ensures perfect seating of disc against body seat**
- Available in a wide range of alloys**

NO.	PART NAME	CF3M	A 351-CN7M
1	BODY	A 351-CF3M	A 351-CN7M
2	DISC	A 351-CF3M	A 351-CN7M
3	DISC CARRIER	A 351-CF3M	A 351-CN7M
4	COVER	A 351-CF3M	A 351-CN7M
5	GASKET	PTFE	PTFE
6	PIN (INTEGRAL)	A 276-316L	A 351-CN7M
7	WASHER	A 276-316L	A 351-CN7M
8	HEX NUT	A 276-316L	A 351-CN7M
9	STUD	A 193-B8	A 193-B8M
10	HEX NUT	A 194-8	A 194-8M

**Designed to ANSI B16.34,  
tested to API 598, ends  
to ANSI B16.11**

CLASS 150							
SIZE	INCH	1/2	3/4	1	1 1/4	1 1/2	2
	MM	15	20	25	31.75	40	50
A	INCH	3.75	3.75	5.0	5.5	6.0	6.5
	MM	95	95	127	139.7	152	165
B	INCH	3.15	3.15	3.15	3.43	3.43	3.78
	MM	80	80	80	87	87	96
CLASS 300							
SIZE	INCH	1/2	3/4	1	1 1/4	1 1/2	2
	MM	15	20	25	31.75	40	50
A	INCH	3.75	3.75	5.0	5.5	6.0	6.5
	MM	95	95	127	139.7	152	165
B	INCH	3.15	3.15	3.15	3.43	3.43	3.78
	MM	80	80	80	87	87	96
CLASS 600							
SIZE	INCH	1/2	3/4	1			
	MM	15	20	25			
A	INCH	3.75	3.75	5.0			
	MM	95	95	127			
B	INCH	3.15	3.15	3.15			
	MM	80	80	80			